



# PT<sup>®</sup>

# THREADING MACHINE

## WARNING!

Read this Operator's Manual carefully before using this tool.  
Failure to understand and follow the contents of this manual may result in electrical shock, fire and/or serious personal injury.



PT<sup>®</sup> Reversible 1/2 HP universal motor.  
Capacity: 1/8"-2" (3mm-50mm) pipe  
On/Off/Reverse switch.

### Specifications

PT<sup>®</sup> Motor: 1/2 HP, universal, reversible motor, single-phase, 25-60 Hz, 115V  
Switch: FOR/OFF/REV and Integral Foot Switch  
Chuck: Speed chuck with replaceable jaws  
Spindle Speed: 38 RPM  
Support Bars: Heavy-duty

### Complete PT<sup>®</sup> Threading Machine Consists of:

- PT<sup>®</sup> Power Drive only with foot switch
- Stand
- Carriage with lever
- Reamer
- Cutter
- Universal die head
- Set 1/2" - 3/4" Universal HSS dies
- Set 1" - 2" Universal HSS dies
- Oiler
- 1 gallon Tuf-Cut<sup>®</sup> thread cutting oil



FOR PRODUCT OR WARRANTY INFORMATION CONTACT  
ARGCO - PIPINGTOOLS DIVISION  
PHONE: 800-854-1015 • FAX: 760-727-3270  
2610 COMMERCE WAY • VISTA, CA 92081  
[www.pipingtools.com](http://www.pipingtools.com)

## General Safety Information

WARNING! Read and understand all instructions. Failure to follow all instructions listed below may result in electric shock, fire, and/or serious personal injury.

### Work Area Safety

- **Keep your work area clean and well lit.** Cluttered benches and dark areas invite accidents.
- **Do not operate power tools in explosive atmospheres, such as in the presence of flammable liquids, gases, or dust.** Tools create sparks which may ignite the dust or fumes.
- **Keep bystanders, children, and visitors away while operating tool.** Distractions can cause you to lose control.
- **Keep floors dry and free of slippery materials such as oil.**
- **Guard or the area when work piece extends beyond machine.** A guard or barricade that provides a minimum of three feet clearance around the work piece will reduce the risk of entanglement.

### Electrical Safety

- **Grounded tools must be plugged into an outlet, properly installed and grounded in accordance with all codes and ordinances.** Never remove the grounding prong or modify the plug in any way. Do not use any adapter plugs. Check with a qualified electrician if you are in doubt as to whether the outlet is properly grounded. If the tool should electrically malfunction or break down, grounding provides a low resistance path to carry electricity away from the user.
- **Avoid body contact with grounded surfaces.** There is an increased risk of electrical shock if your body is grounded.
- **Don't expose electrical tools to rain or wet conditions.** Water entering a tool will increase the risk of electrical shock.
- **Do not abuse cord.** Never use the cord to carry the tools or pull the plug from an outlet. Keep cord away from heat, oil, sharp edges or moving parts. Replace damaged cords immediately. Damaged cords increase the risk of electrical shock.

- When operating a power tool outside, use an outdoor extension cord marked "W-A" or "W". These cords are rated for outdoor use and reduce the risk of electrical shock.
- Use only three-wire extension cords which have three-prong grounding plugs and three-pole receptacles which accept the tool's plug. Use of other extension cords will not ground the tool and increase the risk of electrical shock.
- Use proper extension cords. (See chart.) Insufficient conductor size will cause excessive voltage drop and loss of power.
- **Keep all electric connections dry and off the ground. Do not touch plugs or tool with wet hands.** Reduces the risk of electrical shock.

### Personal Safety

- Stay alert, watch what you are doing and use common sense when operating a power tool. Do not use tool while tired or under the influence of drugs, alcohol, or medications. A moment of inattention while operating power tools may result in serious personal injury.
- **Dress properly.** Do not wear loose clothing or jewelry. Contain long hair. Keep your hair, clothing, and gloves away from moving parts. Loose clothes, jewelry, or long hair can be caught in moving parts.
- **Avoid accidental starting.** Be sure switch is OFF before plugging in. Carrying tools with your finger on the switch or plugging in tools that have the switch ON invites accidents.
- **Remove adjusting keys before turning the tool ON.** A wrench or a key that is left attached to a rotating part of the tool may result in personal injury.
- **Do not overreach.** Keep proper footing and balance at all times. Proper footing and balance enables better control of the tool in unexpected situations.
- **Use safety equipment.** Always wear eye protection. Dust mask, non-skid safety shoes, hard hat, or hearing protection must be used for appropriate conditions.

## Tool Use and Care

- Do not use tool if switch does not turn it ON or OFF. Any tool that cannot be controlled with the switch is dangerous and must be repaired.
  - Disconnect the plug from the power source before making any adjustments, changing accessories, or storing the tool. Such preventive safety measures reduce the risk of starting the tool accidentally.
  - Store idle tools out of the reach of children and other untrained persons. Tools are dangerous in the hands of untrained users.
  - Check for misalignment or binding of moving parts, breakage of parts, and any other condition that may affect the tool's operation. If damaged, have the tool serviced before using. Many accidents are caused by poorly maintained tools.
  - Use only accessories that are recommended for your tool. Accessories that may be suitable for one tool may become hazardous when used on another tool.
  - Keep handles dry and clean; free from oil and grease. Allows for better control of the tool.
- Service
- Tool service must be performed only by qualified repair personnel. Service or maintenance performed by unqualified repair personnel could result in injury.
  - When servicing a tool, use only identical replacement parts. Follow instructions in the Maintenance Section of this manual. Use of unauthorized parts or failure to follow maintenance instructions may create a risk of electrical shock or injury.

## Foot Switch Safety

Using a power drive or threading machine without a foot switch increases the risk of serious injury. A foot switch provides better control by letting you shut off the motor by removing your foot. If clothing should become caught in the machine, it will continue to wind up, pulling you into the machine. Because the machine has high torque, the clothing itself can bind around your arm or other body parts with enough force to crush or break bones.

## Machine Safety

- Power Drive is made to thread and cut pipe or bolt and to power RIDGID roll grooving equipment. Follow instructions on proper use of this machine. Do not use for other purposes such as drilling holes or turning winches. Other uses or modifying this power drive for other applications may increase the risk of serious injury.
- Secure machine to bench or stand. Support long heavy pipe with pipe supports. This practice will prevent tipping.
- Do not wear gloves or loose clothing when operating machine. Keep sleeves and jackets buttoned. Do not reach across the machine or pipe. Clothing can be caught by the pipe or machine resulting in entanglement and serious injury.
- Operate machine from side with REV/OFF/FOR switch. Eliminates need to reach over the machine.
- Do not use this machine if the foot switch is broken or missing. Foot switch is a safety device to prevent serious injury.

**Machine Safety (continued)**

- Keep hands away from rotating pipe and fittings. Stop the machine before wiping pipe threads or screwing on fittings. Allow the machine to come to a complete stop before touching the pipe or machine chucks. This practice will prevent entanglement and serious injury.
  
- Do not use this machine to make or break fittings. This practice is not an intended use of the machine and can result in serious injury.
  
- Tighten chuck handwheel and engage rear centering device on the pipe before turning on the machine. Prevents oscillation of the pipe.
  
- Keep covers in place. Do not operate the machine with covers removed. Exposure to moving parts may result in entanglement and serious injury.
  
- Lock foot switch when machine is not in use  
This will avoid accidental starting.

**Description, Specifications and Standard Equipment**

**Description**

The PT® Power Drive is an electric motor-driven machine which centers and chucks pipe, conduit and rod and rotates it while threading, cutting and reaming operations are performed.

Forward (clockwise) or Reverse (counterclockwise) rotation can be selected with the FOR/OFF/REV switch and a foot switch provides ON/OFF control of the motor.

The threading, cutting and reaming operations can be performed by conventional hand tools or tools designed for mounting on the Power Drive. A manual oiling system is available to flood the workpiece with thread cutting oil during the threading operation. Geared Threaders can also be used with the Power Drive to thread larger diameter pipe.

The PT® Power Drive can also be used as a power source for roll grooving equipment. Designed to attach to the support arms of the Power Drive, the roll grooving equipment forms standard roll grooves on a variety of pipe sizes and materials.

Contact an ARGCO-PT distributor or consult the ARGCO catalog for specifications on roll grooving equipment.

**Specifications**

- Threading Capacity .....Pipe 1/8” through 2”  
Bolt 1/4” through 2”  
Geared Threaders:  
Pipe 2-1/2” through 6”
- Chuck .....Speed Grip Chuck with  
Replaceable Jaw Inserts
- Rear Centering Device....Cam Action Rotates with  
Chuck
- Operating Speed .....38 RPM or 57 RPM
- Motor:  
Type.....Universal
- Horsepower.....1/2 HP

## Machine Assembly

### WARNING

To prevent serious injury, proper assembly of the Power Drive is required. Failure to mount the Power Drive to a stable stand or bench may result in tipping and serious injury. The following procedures should be followed:

### Mounting on Stand

1. Set up the Stand by opening legs and pushing down on the tray. Legs should be stiff and the stand should not wobble.

**NOTE!** The trisland leg stiffness can be increased or decreased by the following procedure:

- Place stand upside down on a flat surface.
- Unlock tray so legs are loose.
- Locate the set screw on the tray leg support on the rear leg (Figure 3).
- Loosen the set screw to make the adjustment. To increase stiffness, move the tray leg support up towards the base. To decrease stiffness, move the tray leg down towards the feet.
- Tighten the set screw (increasing leg stiffness increases tray tension).

2. Mount power drive on the stand using bolts and wing nuts (Figure 3).

## Mounting Carriage Assembly

1. Inspect the support bars to insure they are forward and secured by two (2) retaining ring assemblies. Retaining ring set screws must be tight (Figure 4).
2. Secure eyebolt to the 311A Carriage. Slide lever arm through the eyebolt assembly and secure to collar assembly with shoulder bolt (Figure 4).
3. Tighten collar assembly thumb screw into groove on support bar.
4. Install the 360 Cutter and 341 Reamer by inserting arm in the slot provided in the carriage and secure with the drive pin (Figure 4).
5. Install 811A Die Head by inserting die head post into the mating hole in the carriage.

**NOTE!** When fully inserted, spring-loaded ball will hold die head in place.

## Machine Inspection

### WARNING

To prevent serious injury, inspect your Power Drive. The following inspection procedures should be performed on a daily basis:

1. Make sure Power Drive is unplugged and the directional switch is set to the OFF position (Figure 3).

2. Clean the speed chuck jaws with a wire brush.

3. Inspect the jaw inserts for excessive wear. Refer to the Maintenance Instructions if they need to be replaced.

**NOTE!** For plastic and coated work pieces, special jaw inserts should be used to prevent damaging the workpiece.

4. Make sure the foot switch is present and attached to the Power Drive (Figure 3).

Do not operate the Power Drive without a foot switch.

5. Inspect the power cord and plug for damage. If the plug has been modified, is missing the grounding pin or if the cord is damaged, do not use the Power Drive until the cord has been replaced.

6. Inspect the Power Drive for any broken, missing, misaligned or binding parts as well as any other conditions which may affect the safe and normal operation of the machine. If any of these conditions are present, do not use the Power Drive until any problem has been repaired.

7. Lubricate the Power Drive spindle bearings if necessary according to the Maintenance Instructions.

8. Use tools and accessories that are specifically designed for your Power Drive and meet the needs of your application. The correct tools and accessories allow you to do the job successfully and safely. Accessories suitable for use with other equipment may be hazardous when used with this Power Drive. control slipping from your grip.

9. Clean any oil, grease or dirt from all handles and controls. This reduces the risk of injury due to a tool or Inspect the cutting edges of your tools and dies. If necessary, have them replaced prior to using the Power Drive. Dull or damaged cutting tools and dies can lead to binding, tool breakage and poor quality threads.

10. Clean metal shavings and other debris from the chip tray of the Oiler. Check the level and quality of the thread cutting oil. Replace or add oil if necessary.

**NOTE!** Thread cutting oil lubricates and cools the threads during the threading operation. A dirty or poor grade cutting oil can result in poor thread quality.

## Machine and Work Area Set-Up

To prevent serious injury, proper set-up of the machine and work area is required. The following procedures should be followed to set-up the machine:

1. Locate a work area that has the following:

- Adequate lighting.
- No flammable liquids, vapors or dust that may ignite.
- Grounded electrical outlet.
- Clear path to the electrical outlet that does not contain any sources of heat or oil, sharp edges or moving parts that may damage electrical cord.
- Dry place for machine and operator. Do not use the machine while standing in water.
- Level ground.

2. Clean up the work area prior to setting up any equipment. Always wipe up any oil that may have splashed or dripped from the machine or oiler to prevent slips and falls.

3. Set up the Power Drive on a flat, level surface.

- For a Power Drive mounted on a Stand, open legs of stand and push down on the tray.

Legs should be stiff and stand should not wobble.

**NOTE!** To increase or decrease leg stiffness, refer to instructions on "Mounting On Stand".

## Machine and Work Area Set-Up

4. If the workpiece extends more than four (4) feet beyond the Power Drive, use one or more pipe stands to prevent tipping and the oscillation of the pipe.
5. If the workpiece extends beyond the Power Drive, setup guards or barricades to create a minimum of three (3) feet of clearance around the Power Drive and workpiece. This “safety zone” prevents others from accidentally contacting the machine or workpiece and either causing the equipment to tip or becoming entangled in the rotating parts.
6. If necessary, fill the Oiler with Tuf-Cut Thread Cutting Oil. Position the oiler under the front of the Power Drive (Figure 3).
7. Make sure FOR/OFF/REV switch is in the OFF position.
8. Position the foot switch so that the operator can safely control the machine, tools and workpiece. As shown in Figure 8, it should allow the operator to do the following:
  - Stand facing the directional switch.
  - Use the foot switch with his left foot.
  - Have convenient access to the directional switch, tools and chucks without reaching across the machine.Machine is designed for one person operation.
9. Plug the Power Drive into the electrical outlet making sure to position the power cord along the clear path selected earlier. If the power cord does not reach the outlet, use an extension cord in good condition.

## WARNING

To avoid electrical shock and electrical fires, never use an extension cord that is damaged or does not meet the following requirements:

- The cord has a three-prong plug similar to shown in Electrical Safety section.
- The cord is rated as “W” or “W-A” if being used outdoors.
- The cord has sufficient wire thickness (14 AWG below 25'/12 AWG 25' - 50'). If the wire thickness is too small, the cord may overheat, melting the cord's insulation or causing nearby objects to ignite.

To reduce risk of electrical shock, keep all electrical connections dry and off the ground. Do not touch plug with wet hands.

10. Check the Power Drive to insure it is operating properly.
  - Flip the directional switch to FOR (Forward). Press and release the foot switch. Check that the Power Drive rotates in a counterclockwise direction as you are facing the front chuck. Have the Power Drive serviced if it rotates in the wrong direction or if the foot switch does not control its stopping or starting.
  - Depress and hold the foot switch. Inspect the moving parts for misalignment, binding, odd noises or any other unusual conditions that may affect the safe and normal operation of the machine. If such conditions are present, have the power drive serviced.
  - Flip the directional switch to REV (Reverse). Press and release the foot switch. Check that the Power Drive rotates in a clockwise direction as you are facing the chuck.
  - Release the foot switch and flip the directional switch to OFF.



## Operating Instructions For Using Hand Tools

Do not wear gloves or loose clothing when operating Power Drive.  
Keep sleeves and jackets buttoned.

Do not reach across the machine or pipe.

Do not use this Power Drive if the foot switch is broken or missing.

Always wear eye protection to protect eyes from dirt and other foreign objects.

Keep hands away from rotating pipe and fittings.

Stop the machine before wiping pipe threads or screwing on fittings.

Allow the machine to come to a complete stop before touching the pipe or machine chucks.

Do not use this machine to “make-on” or “break off” fittings. This practice is not an intended use of this Power Drive.

### Installing Pipe In Power Drive:

1. Mark the pipe at the desired length if it is being cut to length.
2. Insert the pipe into the Power Drive so that the end to be worked or the cutting mark is located about 12” to the front of the speed chuck jaws.
3. Insert workpieces less than 2 feet long from the front of the machine. Insert longer pipes through either end so that the longer section extends out beyond the rear of the Power Drive.  
To avoid equipment tip-overs, position the pipe supports under the workpiece.
4. Tighten the rear centering device around the pipe by using a counterclockwise rotation of the handwheel at the rear of the Power Drive. This prevents movement of the pipe that can result in poor thread quality.
5. Secure the pipe by using repeated and forceful counterclockwise spins of the speed chuck handwheel at the front of the Power Drive. This action “hammers” the jaws tightly around the pipe.
6. Extend both support bars fully beyond the front of the Power Drive.

### Cutting Pipe with Hand Cutter

1. Position the pipe cutter on the workpiece with the cutter wheels facing up (see “Accessories” section for pipe cutters recommended for use with this Power Drive).
  2. Align the cutter wheels with the mark on the pipe and rest the pipe cutter’s body on the left support bar (Figure 5). Hand-tighten the pipe cutter to the workpiece using the feedscrew handle while keeping the cutter wheels aligned with the mark.
  3. Assume the correct operating posture (Figure 8). This will allow you to maintain proper balance and to safely keep control of the machine and tools.
    - Be sure you can quickly remove your foot from the foot switch.
    - Stand facing the directional switch.
    - Be sure you have convenient access to directional switch, tools and chucks.
    - Do not reach across the machine or workpiece.
  4. Flip the directional switch to FOR (Forward).
  5. Grasp the pipe cutter’s feedscrew handle with both hands (Figure 5) and depress and hold down the foot switch with the left foot.
  6. Tighten the feedscrew handle slowly and continuously until the pipe is cut. Do not force the cutter into the workpiece.
- WARNING:** To avoid impact injuries, keep a firm grip on the pipe cutter and be sure it is resting on the support bar. If not held firmly or supported, the tool may rotate or fall to the ground.
7. Release the foot switch and remove your foot from the housing.



### Reaming Pipe with Hand Reamer

**WARNING:** To prevent serious injury, do not use selffeeding spiral reamers with the 300 Power Drive.

1. Flip the directional switch to FOR (Forward).
2. Place the reamer in the end of the pipe (see the “Accessories” section for reamers recommended for use with this Power Drive).
3. Assume the correct operating posture.
4. Rest handle on the left support bar (Figure 6) and hold the reamer handgrip with the right hand. To avoid pinch point injuries, keep your fingers from coming between the reamer and the support bar.
5. Firmly grasp the end of the reamer handle with the left hand, then depress and hold the foot switch down.
6. Push the reamer firmly into the pipe with your right hand until ream is complete. Keep your hand and arm away from any rotating parts and use a firm grip on the handgrip.
7. Release the foot switch and remove your foot from the housing while holding the reamer with both hands.
8. Remove the reamer from the workpiece once the Power Drive has stopped rotating.

### Threading Pipe with Hand Threader

1. Place the die head of the hand threader on the end of the pipe (see “Accessories” section for hand threaders recommended for use with this Power Drive).
2. Position the ratchet knob on the hand threader so that the arrow on the knob points up.
3. Rest the hand threader ratchet handle on the left support bar (as viewed when facing the front of the Power Drive – Figure 7).

**WARNING:** To avoid pinch point injuries, keep your fingers from coming between the hand threader and the support bar.

4. Apply Tuf-Cut Thread Cutting Oil to the end of the pipe.
5. Assume the correct operating posture. Check to ensure directional switch is in the FOR (Forward) position.
6. Hold the die head against the workpiece with the right hand.

**WARNING:** To avoid injury from rotating parts or sharp surfaces, keep hands and fingers away from anything other than the outer body of the die head.

7. Depress and hold down the foot switch.
8. Push the die head against the pipe using the palm of the right hand until the dies engage the workpiece. Once engaged, the threads will be cut as the dies pull themselves onto the end of the pipe (Figure 7).
9. Remove the right hand from the area of the die head and liberally oil the dies while the pipe is threaded (Figure 8).

**WARNING:** To avoid serious injury from rotating parts, allow adequate clearance between your hand and the rotating parts while oiling.

10. Release the foot switch and remove your foot from the housing when the pipe reaches the end of the dies.
11. Lift the threader handle slightly with the right hand while sliding the left support bar all the way toward the rear of the drive.

12. Reverse the ratchet knob. The arrow on the knob should point down.
13. Lower the threader handle below the height of the left support bar.
14. Slide the left support bar back to its fully extended position in front of the Power Drive.
15. Lift and hold the threader handle against the left support bar.
16. Flip the directional switch to REV (Reverse). Depress and hold the foot switch down until the threader has unscrewed itself from the workpiece.

To avoid injury due to falling parts, maintain a firm grip on the threader as the threader will drop to the floor if not supported when unthreaded completely.

17. Release the foot switch and remove your foot from the housing.
18. Set the threader down and, if necessary, wipe oil and debris off the threads with a rag, taking care not to cut your hand or fingers on any sharp debris or edges.
19. Check the thread for length and depth (Figure 14).

### **Removing Pipe from the Power Drive**

1. Flip the directional switch to OFF.
2. Use repeated and forceful clockwise spins of the speed chuck handwheel at the front of the Power Drive to release the workpiece from the speed chuck jaws.
3. If necessary, loosen the rear centering device using a clockwise rotation of the handwheel at the rear of the Power Drive.
4. Slide the workpiece out of the Power Drive, keeping a firm grip on the workpiece as it clears the Power Drive.

To avoid injury from falling parts or equipment tip-overs when handling long workpieces, make sure that the end farthest from the Power Drive is supported prior to removal.

5. Clean up any oil spills or splatter on the ground surrounding the Power Drive.

**Carriage with Lever**

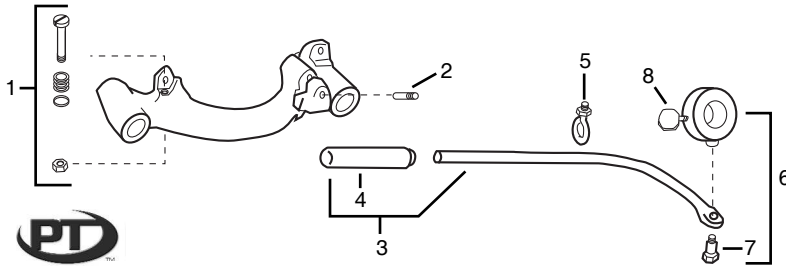

REF	PART #	DESCRIPTION
-	33-02-100	Carriage with lever
-	33-02-100A	Carriage Lever kit (incl. 3, 5, 6, 8)
1	33-02-101	Carriage stop bolt assembly
2	33-02-103	Carriage reamer hinge pin
3	33-02-104	Carriage lever arm assembly
4	33-02-105	Carriage handgrip
5	33-02-106	Carriage eye bolt assembly
6	33-02-107	Carriage collar assembly
7	33-02-108	Carriage shoulder bolt
8	33-02-114	Carriage thumbscrew
	33-01-100	Carriage Assembly Complete

**Reamer**

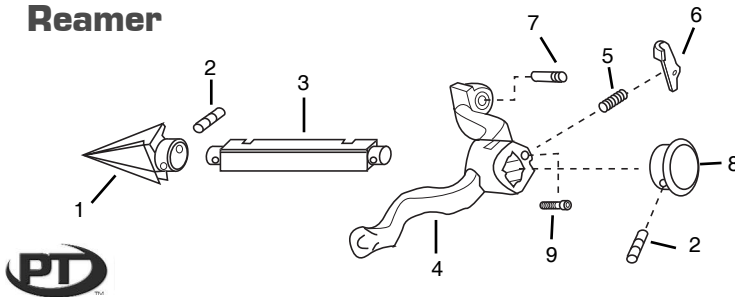

REF	PART #	DESCRIPTION
-	33-02-200	Reamer complete
1	33-02-201	Reamer cone
2	33-02-202	Reamer pin
3	33-02-203	Reamer bar
4	33-02-204	Reamer arm
5	33-02-205	Reamer latch spring
6	33-02-206	Reamer latch
7	33-02-103	Reamer hinge pin
8	33-02-208	Reamer knob
9	33-02-209	Reamer Screw 1/4" - 20 x 3/4"

**Cutter**

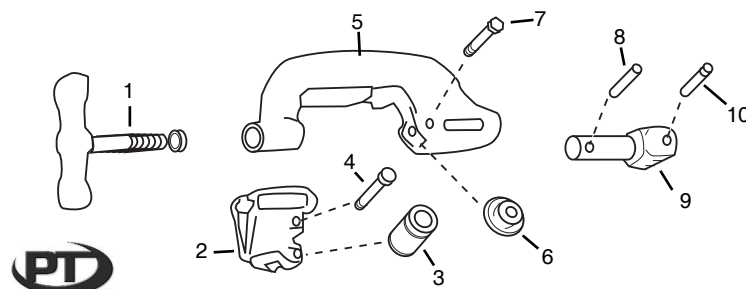

REF	PART#	DESCRIPTION
-	33-02-300	Cutter complete
1	33-02-301	Cutter screw handle
2	33-02-302	Cutter roll housing assy
3	33-02-303	Cutter roll
4	33-02-304	Cutter roll pin
5	33-02-305	Cutter frame
6	33-02-306	Cutter wheel HD
	33-02-306A	Cutter wheel standard
7	33-02-307	Cutter wheel pin
8	33-02-308	Cutter retaining pin
9	33-02-309	Cutter support arm
10	33-02-310	Cutter hinge pin

**Universal Die Head**

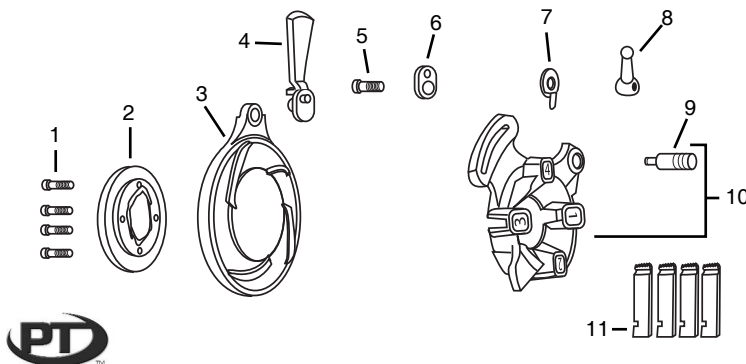

REF	PART#	DESCRIPTION
-	33-02-400	Diehead complete NPT
1	33-02-401	Diehead Screw 1/4" - 20 x 5/8" SHCS (2)
2	33-02-402	Diehead retaining ring
3	33-02-403	Diehead cam plate
4	33-02-404	Diehead throw out lever
5	33-02-405	Diehead lock screw
6	33-02-406	Diehead link
7	33-02-407	Diehead lever washer
8	33-02-408	Diehead clamp lever
9	33-02-409	Diehead post
10	33-02-410	Diehead head with post
11	33-04-302	Dies universal 1/2" & 3/4" NPT
	33-04-303	Dies universal 1" to 2" NPT

**Stand**

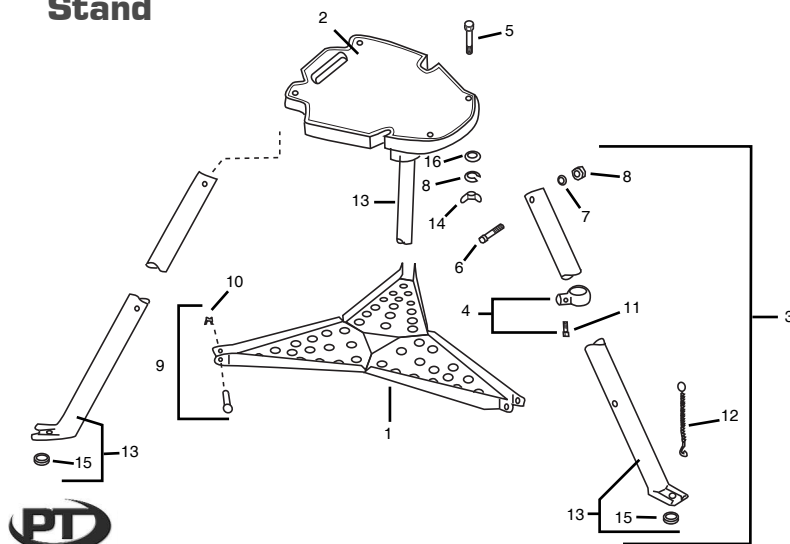

REF	PART #	DESCRIPTION
-	33-03-100	Stand complete
1	33-03-101	Stand tool tray
2	33-03-102	Stand base
3	33-03-103	Stand tray & leg assembly
4	33-03-104	Stand tray support w/screws
5	33-03-105	Stand bolt 3/8"-16 x 2" (5)
6	33-03-106	Stand bolt 3/8"-16 x 2-3/4" (5)
7	33-03-107	Stand nut 3/8"-16 (5)
8	33-03-108	Stand lock washer 3/8" (5)
9	33-03-109	Stand pin with washer (3)
10	33-03-110	Stand washer (3)
11	33-03-111	Stand set screw 3/8" - 16 x 1"
12	33-03-112	Stand leg chain
13	33-03-113	Stand front & rear leg
14	33-03-115	Stand wing nut 3/8" - 16 (5)
15	33-03-116	Stand grommet (5)
16	30-03-117	Stand washer 3/8" (5)

**Oiler**

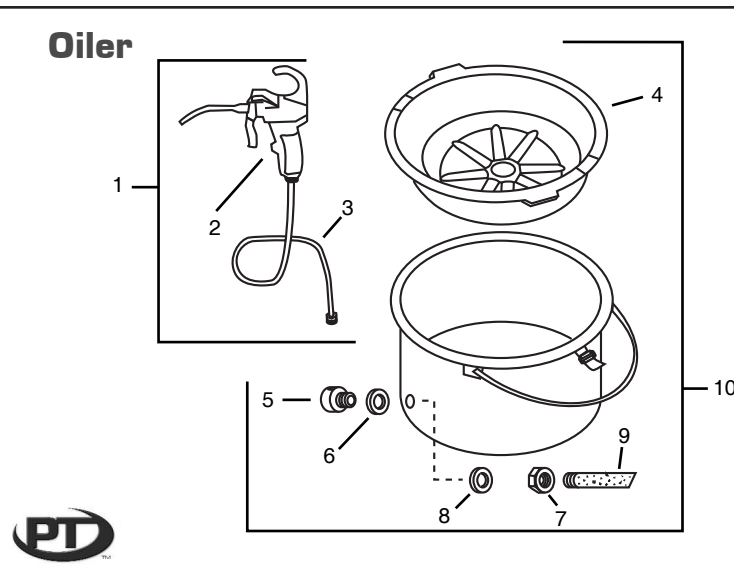

REF	PART #	DESCRIPTION
-	33-03-200	Oiler complete
1	33-03-201	Oiler pump gun w/hose & fittings
2	33-03-202	Oiler pump gun
3	33-03-203	Oiler hose w/fitting
4	33-03-204	Oiler drip pan
5	33-03-205	Oiler drip pan coupling
6	33-03-206	Oiler drip pan washer metal
7	33-03-207	Oiler drip pan hex nut
8	33-03-208	Oiler drip pan washer rubber
9	33-03-209	Oiler drip pan strainer
10	33-03-210	Oiler bucket (incl. 4-9)

**THREADING MACHINE REPLACEMENT PARTS**

**Electrical Components**

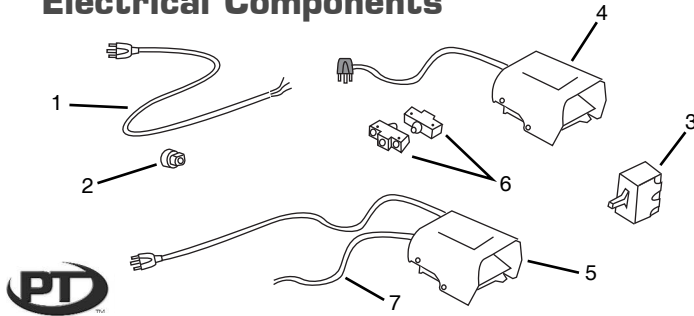

REF	PART #	DESCRIPTION
1	33-03-305	EC power cord with plug (115V)
2	33-03-307	EC power cord grommet
3	33-03-311	EC switch
4	33-03-312	EC foot switch (remote)
5	33-03-314	EC foot switch (hardwired)
6	33-03-320	EC micro switch for foot switch
7	33-03-321	EC line cord for foot switch

**Wiring Diagram**

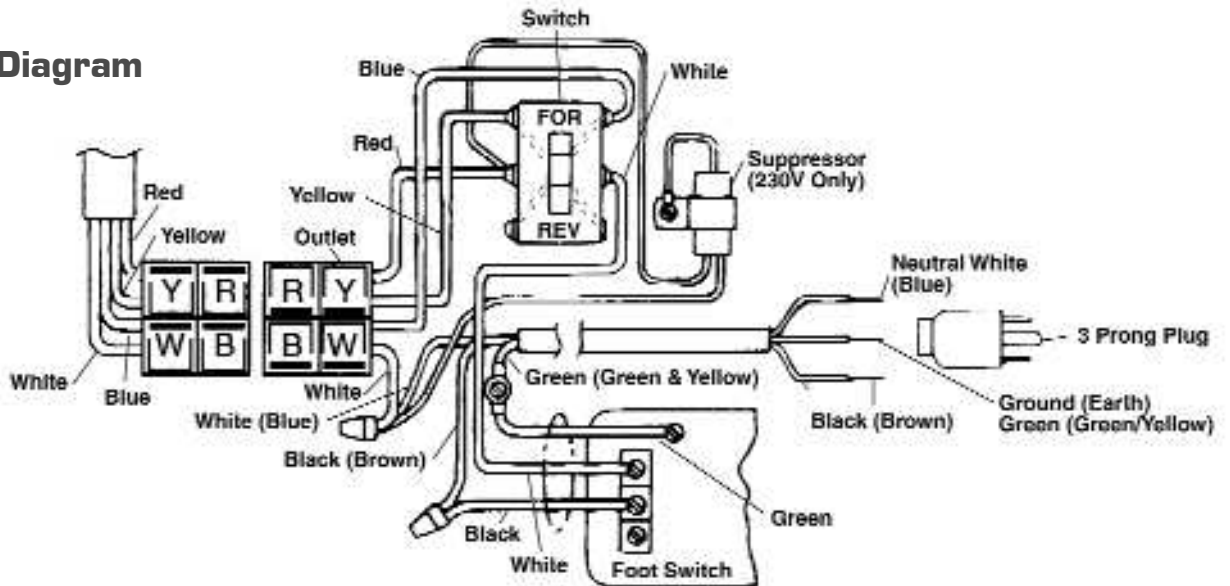

**Motor Components**

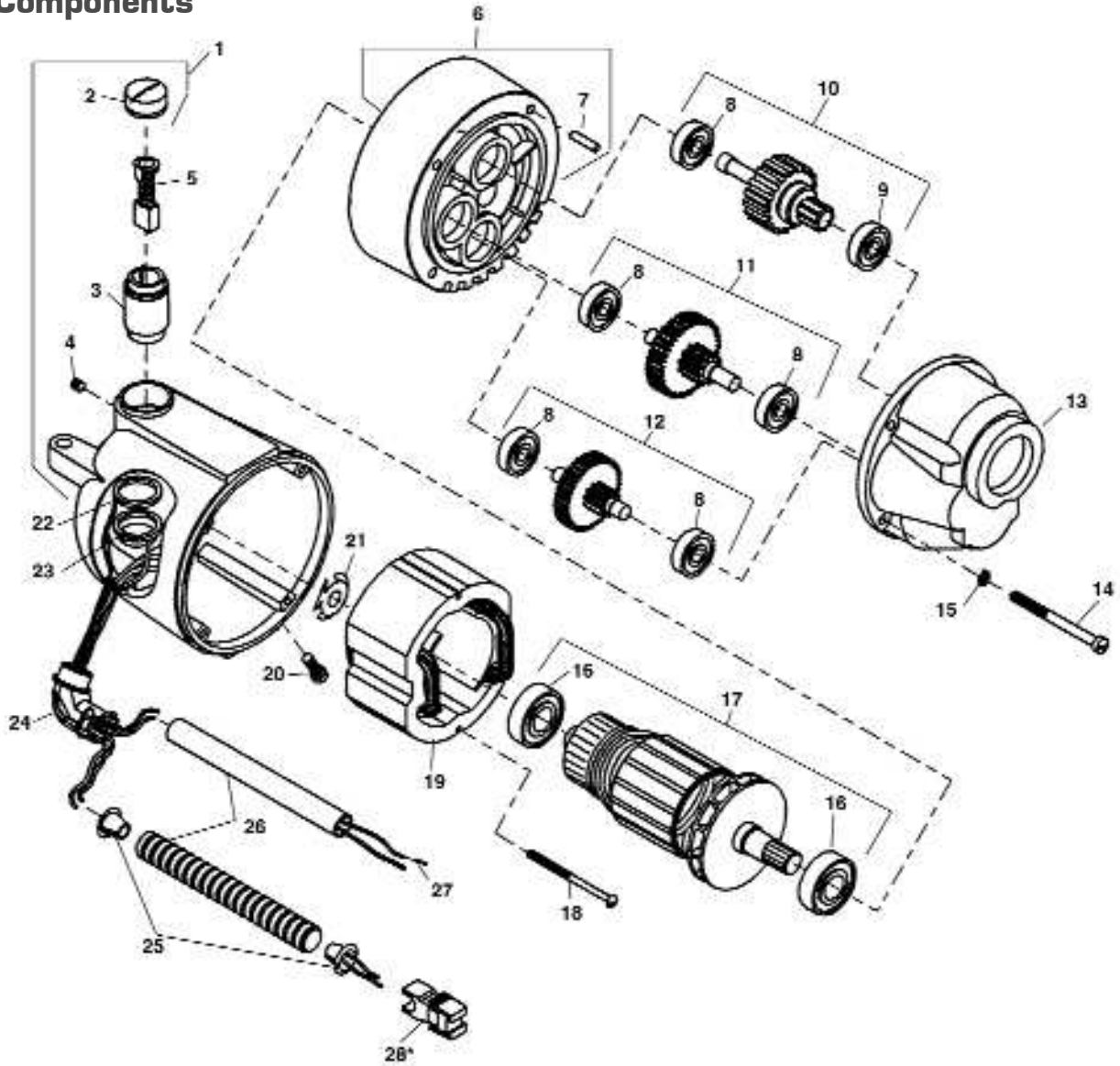

REF	DESCRIPTION
-	PT Motor 115V
1	Housing Assembly
2	Brush Cap Set
3	Brush Holder Set
4	Set Screw (2)
5	Brush Assembly Set
6	Fan Housing Assembly
7	Dowel Pin
8	Gear Bearings (5)
9	Front Bearing

REF	DESCRIPTION
10	Drive Gear
11	1st Gear Assembly
12	2nd Gear Assembly
13	Gear Housing
14	Screw (4)
15	Lock Washer
16	Armature Bearing (2)
17	Armature (115V)
18	Mounting Screw (2)
19	Field (115V)

REF	DESCRIPTION
20	20Locking Screw
21	Loading Spring
22	White Upper Lead
23	Red Lower lead
24	Connector 90 Degree
25	Insulator (2)
26	Flexible Conduit
28	Plug (Included in Switch Box Assy)







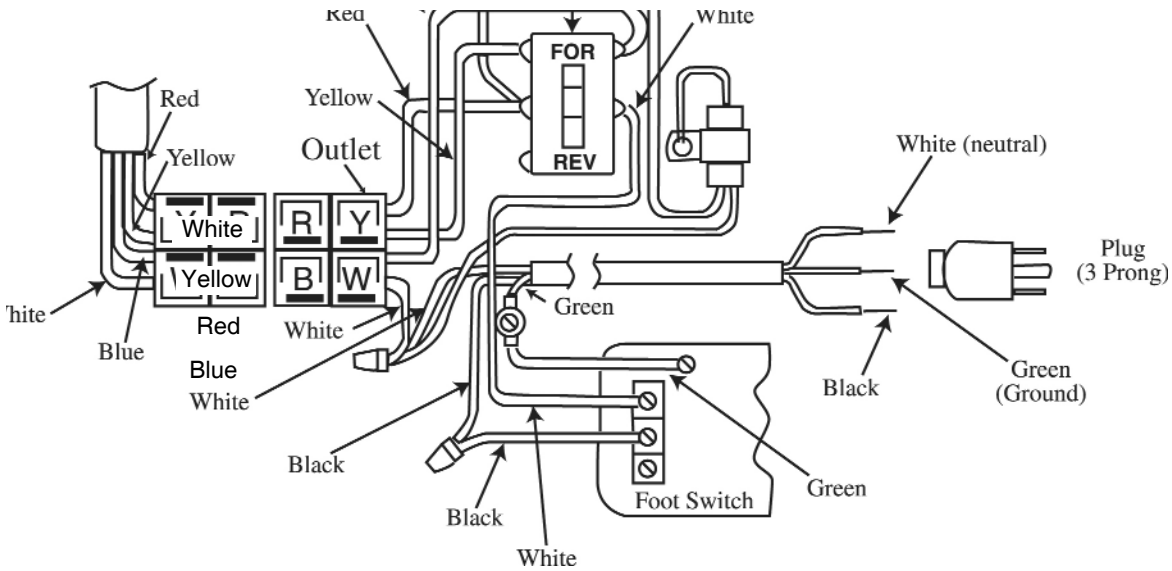

**PT® THREADING MACHINE REPLACEMENT PARTS**

**Universal Dies**



PART #	DESCRIPTION
33-04-301	Dies universal HSS 1/4" & 3/8"
33-04-302	Dies universal HSS 1/2" & 3/4"
33-04-303	Dies universal HSS 1" to 2"
33-04-305	Dies universal stainless 1" to 2"
33-04-311	Dies grooving 1" to 2"
33-04-320	Dies geared threader 2-1/2" to 4"
ROTH00028A	Dies Universal/SOM 1" to 2" for 22A

**POWER DRIVE ACCESSORIES**

**Splatter Guard**



- Keep threading oil & chips in the oiler and off the walls and floor.
- Easily attaches to threading machine.

**Transporter**



Transport power drive by rolling, without heavy lifting.

PART #	DESCRIPTION
33-04-400	PD splatter guard
33-04-401	PD tric tray
33-04-403	PD transporter



**Tric Tray**

Heavy duty tray with V notch for pipe. Easily attaches to threading machine. No removeable parts to break or lose.



## ONE YEAR WARRANTY:

ARGCO stands behind all PT® tools - no questions asked.

All PT® tools are warranted to be free of defects in workmanship and material.

### **How long coverage lasts:**

This warranty lasts one year from date purchased. Warranty coverage ends when the product becomes unusable for reasons other than defects in workmanship or material.

### **Service:**

To obtain warranty benefits, ship product to ARGCO, Ft Smith, Arkansas. Warranted products will be repaired or replaced, at ARGCO's option, and returned at no charge.

### **What is not covered:**

Failures due to misuse, abuse or normal wear and tear are not covered by this warranty. ARGCO shall not be responsible for any incidental or consequential damages.

### **No Other Express Warranty Applies**

This Full One Year Warranty is the sole and exclusive warranty for ARGCO products. No employee, agent, dealer, or other person is authorized to alter this warranty or make any other warranty on behalf of the ARGCO Inc.



FOR PRODUCT OR WARRANTY INFORMATION CONTACT  
ARGCO - PIPINGTOOLS DIVISION  
PHONE: 800-854-1015 • FAX: 760-727-3270  
2610 COMMERCE WAY • VISTA, CA 92081  
[www.pipingtools.com](http://www.pipingtools.com)