

FIRE HOSE VALVES (GROOVED)



2-1/2" STANDARD ANGLE HOSE VALVE
2-1/2" GROOVED INLET X 2-1/2" MALE HOSE OUTLET



Heavy Duty 2-1/2" (65 mm) angle hose, 300 lb (2070 KPa) pressure tested approved valve.
Lightweight cast brass body, Forgeline Bonnett and Seat Assembly. UL/ULC listed and FM Approved. Specify regional hose thread for outlet.

FINISH: Cast Brass

OPTIONS: Chrome Plated, Polish Brass, Polish Chrome

HOSE THREADS AVAILABLE: CSA, BCT, WCT, QST, NSST, NPSH, NST, Louisville, Cleveland, Chicago, Pittsburgh, New Cincinnati, New York Corp., New York Fire Department, Richmond, Raleigh

Model # IE23G | Item #6520010-GROOVED:
Angle Hose Valve Cast Brass
2-1/2" (F) NPT x 2-1/2"(M) NST

Dimensions:

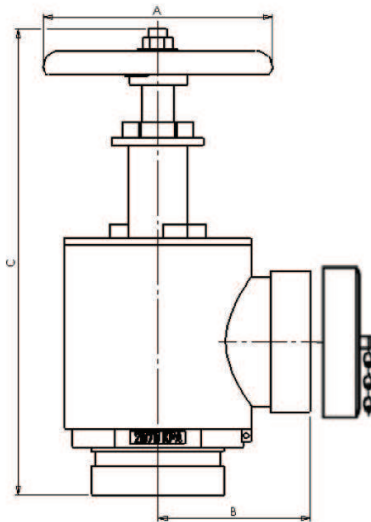

A: 5" (125 mm)
B: 3-3/16" (79 mm)
C: 11.8" open (300 mm)
10.5" closed (267 mm)

Weight: 9 lbs (4.09 kg)
Working Pressure: 300 # (2070 kpa)

The information contained herein is produced in good faith and is believed to be reliable but is for guidance only. ARGCO and its agents cannot assume liability or responsibility for results obtained in the use of its product by persons whose methods are outside or beyond our control. It is the user's responsibility to determine the suitability of any of the products, methods of use, or preparation prior to use, mentioned in our literature. It is the user's responsibility to observe and adapt such precautions as may be advisable for the protection of personnel and property in the handling and use of any of our products.

**FOR MORE INFORMATION CALL ARGCO AT 800-854-1015
OR LOG ONTO ARGCO.COM**