

GRUV MASTER

USER MANUAL

Model GHM-2X

ELECTRIC HYDRAULIC ROLL GROOVING MACHINE



**THE TRUE MASTER
OF ROLL GROOVING**

WARNING:

Read this Operator's Manual carefully before using this tool. Failure to understand and follow the contents of this manual may result in electrical shock, fire and/or serious personal injury.

GENERAL SAFETY REQUIREMENTS

Work Area Safety

- Keep work zone **clean and lighted**. Cluttered or dark areas may bring accidents.
- **Do not operate groover in explosive atmospheres**, such as in the presence of flammable liquids, gases, or dust. Groover creates sparks which may ignite the dust or fumes.
- **Keep children and irrelevant person away** while operating a groover.
- Keep floors dry and **free of slippery materials** such as oil.

Personal Safety

- **Stay alert** while operating a groover. Do not use a groover while fatigued or under the influence of drugs, alcohol, or medication. Inattention when using groover may result in serious personal injury.
- Use **personal protective equipment**. Always wear eye glasses.
- **Remove any adjusting rulers or wrench before using groover**. Tools left attached to a rotating part of the groover may result in personal injury.
- **Dress properly**. Do not wear loose clothing or jewelry. Keep hair, clothing, and gloves away from moving parts.

Electrical Safety

- **Power tool plugs must match the outlet. Never modify the plug in any way**. Do not use any adapter plugs with grounded (earthed) power tools. Unmodified plugs and matching outlets will reduce risk of electric shock.
- **Avoid body contact with grounded or earthed surfaces, such as pipes or radiators**. There is an increased risk of electric shock if personal body is grounded.
- **Do not expose power tools to rain or wet conditions**. Water entering a power tool will cause electric shock.
- **Do not abuse the cord. Never use the cord for carrying, pulling or unplugging the power tool. Keep cord away from heat, oil, sharp edges or moving parts**. Damage or entangled cords increase the risk of electric shock.
- **When operating a power tool outdoors, use an extension cord suitable for outdoor use**.
- **If operating a power tool in a damp location, use a Ground Fault Circuit Interrupter (GFCI) protected supply**.

Power Tool Use and Care

- **Always use the correct power tool for each application.** The correct power tool will do the job right and safer at the rate for which it was designed.
- **Do not use the power tool if the switch does not turn it ON and OFF.** Any power tool that cannot be controlled with the switch is dangerous and must be repaired.
- **Disconnect the plug from the power source before making any adjustments, changing accessories or storing power tools.**
- **Store idle tools away from children** and do not allow persons unfamiliar with the tool or these instructions to use the groover. Roll groover is dangerous in the hands of untrained users.
- **Maintain tools.** Check for misalignment or binding of moving parts, breakage of parts and any other condition that may affect the tool's operation. If damaged, have the tool repaired before use.
- Use only accessories that are recommended for GRUVMASTER® GHM-2X Electronic Hydraulic Roll Groover.
- **Keep handles dry and clean;** free from oil and grease.

Service

- **Have the roll groover serviced only by a qualified repair person using identical replacement parts.**

Contact GRUVMASTER® Technical Service team at +86-139 1870 8873 or customerservice@GRUVMASTER.com.cn if any questions.

Foot Switch Safety

Using the electric roll groover without a foot switch increases the risk of serious injury. A foot switch provides better control by letting the operating personnel shut off the motor by simply removing foot. If clothing should become caught in the machine, it will continue to rolling in and pulling personnel into the machine. Because the roll groover has high torque, the clothing itself can bind around arm or other body parts with enough force to crush or break bones.

Roll Groover Safety

- **Keep hands away from grooving rolls.** Do not wear loose fitting gloves.
- **Keep hands away from ends of pipe.** Burrs and sharp edges may catch and cut.
- **Properly support the pipe** to prevent the tipping of the pipe and equipment.
- **Set-up the groover on a flat, level surface.** Be sure the machine, stand and groover are stable.
- **Always wear appropriate personal protective equipment** such as protection glasses, tight fitting leather gloves, steel toed footwear, and a hardhat.
- **Do not wear loose clothing. Keep sleeves and jackets buttoned. Do not reach across the machine or pipe.** Clothing can be caught by the pipe resulting in entanglement and serious injury.
- **Do not use this groover without a foot switch.** Foot switch is a safety device to prevent serious injury.
- **Only use roll groover to groove pipe of recommended sizes and types according to this instruction.** Improper use or modification of the roll groover for other applications may increase the risk of injury.



DESCRIPTION, SPECIFICATIONS and STANDARD EQUIPMENT DESCRIPTION

GRUVMaster® GHM-2X Heavy Duty Electric Hydraulic Roll Groover is a motor driven roll groover designed with an advanced hydraulic feeding system. It can form roll grooves in steel and aluminum pipe of **2" thru 12" diameter, SCH 7, SCH10 and SCH40**. It is also designed to groove 2" to 10" schedule 10 and 2" to 8" schedule 40 stainless steel pipe. The grooves are formed by mechanically advancing a grooving roll into the pipe which is supported by a knurl drive roll. The only adjustment necessary is for the depth of the groove. The GRUVMaster® GHM-2X HD Electric Hydraulic Roll Groover is designed for **heavy volume work** on job site and for workshop in-house fabrication.



Specifications

Capacity	2" – 12" Schedule 10 and Schedule 40 Steel pipe with roll change (See Chart A for groove specification)
Max. allowance of pipe thickness.....	10mm / 0.40inch
Max. hydraulic pressure of cylinder.....	40Mpa / 400 bars / 5700psi
Max. extrusion force.....	8,000kgs / 17,600lbs
Capacity of hydraulic oil reservoir.....	200mL / 6¾ fl.oz.
Grooving speed (w/ 1400rpm gear motor)	23rpm
Groove Diameter Lock device.....	Stop knob
Operation Methods.....	Single phase motor 1100W / 110~240V / 50/60Hz , or Three phase motor 750W / 380V / 50/60Hz (optional)
Actuation.....	Hydraulic Hand Pump
Weight	approx.130 kgs/ 290lbs.
Packing size L×W×H	820mm×470mm×880mm / 32.3"×18.5"×34.7"
Groove specification.....	AWWA C606-87

GROOVING PROCESS

Work Area & Machine Set-up

1. Make sure the work area follows:
 - Adequate lighting
 - No flammable liquids, vapors or dust that may ignite.
 - Grounded electrical outlet
 - Clear path to the electrical outlet without any oil, sharp edges or moving parts which may damage the electric cord.
 - Dry place for machine and operator. Do not use the machine when standing in water.
 - Level ground
 - Clean up the work area prior to setup any equipment.
2. Use **two people** to lift the roll groover and third person inserts four support legs in to the base sockets. **Refer to Figure A.**

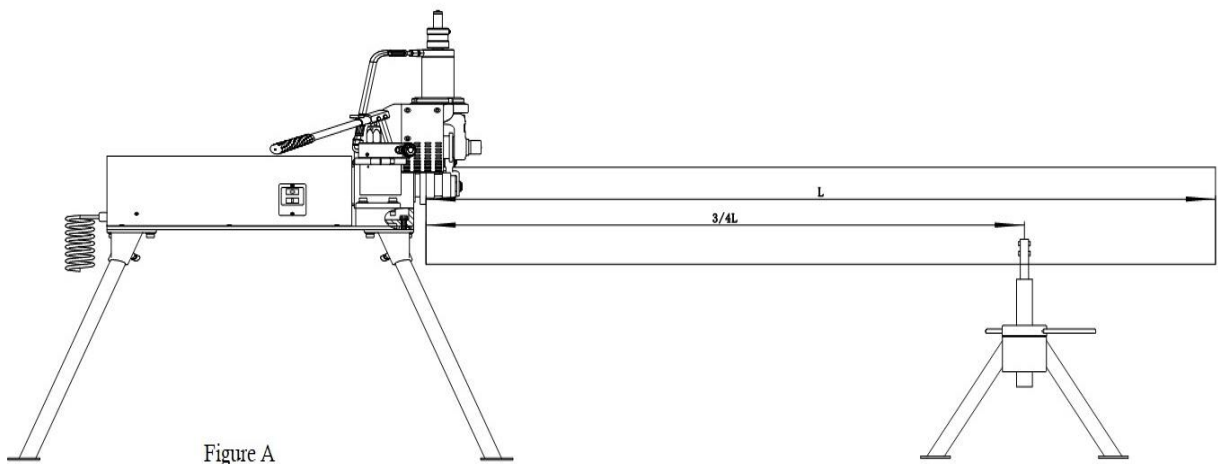

3. Turn the upper portion of the leg until the foot makes full contact with ground. Adjust all four legs until the machine is level. Secure set screws to fix legs.
4. Install pump handle with pin attached.
5. Make sure the power switch is in the OFF position.
6. Place the foot switch so that the operator can safely control the roll groover and workpiece. It should allow the operator to do the following:
 - Stand facing the hydraulic pump.
 - Control the foot switch with left foot.
 - Have convenient access to the groover and hydraulic pump without reaching across the machine.
7. Plug the machine into the power socket and make sure cord is in good & safe condition.
8. Inspect the roll groover as following steps:

- Turn the power switch in ON position.
- Press and release the foot switch. Check that the groove roll rotates in a counterclockwise direction as the operator faces the groover.
- Depress the foot switch and hold. Inspect all moving parts for misalignment, binding, odd noise or any other unusual conditions.
- Release foot switch and turn the power switch in OFF position.
- If any founding that may affect the safe and normal operation of the machine, have the roll groover repaired before use.

Pipe Preparation

These are generalized instruction only. Always follow grooved coupling manufacturer's specific recommendations for pipe end preparation. Failure to follow the grooved coupling manufacturer's recommendations may lead to an improper connection and cause leaks.

1. Cut pipe to proper length. Make sure pipe end is cut square and free of burrs. Cut off method and large burrs can affect the quality of the groove made and the tracking of the groove. Do not attempt to groove pipe that has been cut with a torch.
2. All internal/external weld bead, flash, or seams must be ground flush at least 2" back from the end of the pipe. Do not cut flats into gasket seat area, this could cause leaks.
3. Remove all scale, dirt, rust and other contaminants **at least 2"/50mm back** from the end of the pipe. Contaminants can clog the drive knurls and prevent proper driving and tracking of the pipe while grooving.
4. Make sure that the pipes to be grooved have appropriate support. When using one pipe stand, make sure the stand supports the pipe at the place where 3/4 of the total length from the grooved end. Refer to Figure A.
5. Pipes equal or **over 108"/3.0meter** should be supported with **at least two pipe stands**. Locate each stand at the 1/3 point of the pipe. Failure to properly support the pipe may allow the pipe or the pipe and machine to tip and fall.
6. Square pipe and pipe support to roll groover making sure pipe is flush against drive roll plate.
7. Verify that the pipe is level or sloped slightly downward away from the operator (pipe stand slightly lower than the groove machine about 1°-2°).
8. Turn the power switch to ON position, depress the foot switch and hold. Observe the pipe rotation. If the pipe turns spiral and tends to "walk off" the drive roll, check setup and level status of the pipe. If correct, slightly offset the pipe and pipe stands approximately 1°-2° degree (about 2" over at 10 feet/ 50mm over at 3.0meters from the roll groover) away from the operator. Recheck the rotation until pipe turns stable.

Start A Test Grooving

A test grooving should be always performed when setting up or changing pipe sizes.

1. Turn the pump knob clockwise, in “ON” direction, till full close. Press down the pump lever to push down the groove roll in contact with the pipe top surface.
2. Turn down the stop knob clockwise until it contacts the oil cylinder top surface. The pipe and roll groover should be secure to each other at this stage. Refer to Figure 3.
3. Depend on required groove depth (refer to Chart B “Groove Parameters”), turn up the stop knob counter-clockwise. Each full circle is approximately 1/16” (2mm).
4. Turn the gear of the pipe stabilizer clockwise until the stabilizer stay in touch with pipe body.
5. Start the roll groover by step on the foot switch while pressing down the pump lever. Allow one full pipe rotation between half strokes of the pump lever.
6. When the stop knob contacts the cylinder top surface, allow two more full pipe rotation.
7. Stop the roll groover by releasing foot switch. Loose the pump knob counter-clockwise and perform groove inspection. Use groove tape to check groove diameter.
8. If the groove is too large, the groover can be adjusted and the groove will be made smaller by turning stop knob counter-clockwise slightly. Repeat steps 4 -6. If the groove is too small, turn the stop knob clockwise slightly. Another groove will need to be made. Proper groove diameter is important to insure connection performance. Out of specification grooves could cause joint failure.

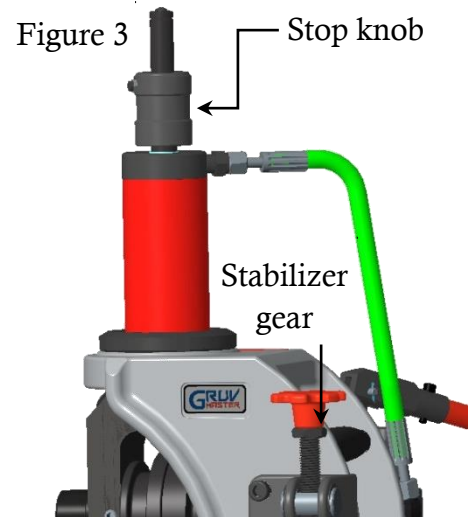

Roll grooving with GHM-2X

1. After the test grooving is made and the groove meets requirement, make sure the stop knob is in touch with oil cylinder surface. The roll groover is ready to operate on pipes in the same size.
2. Repeat “Pipe Preparation” section and steps 4-7 in “Start a test groove” for more grooving.
3. **Implement at least one groove diameter inspection after every 5 grooves are formed.**

Changing Roll Sets

1. Open the relief valve on hydraulic pump counterclockwise and raise the groove roller to the top position. Refer to Figure 4.
2. Remove Groove Roll
Loose the setscrew on the side block with a 3/16" (5mm) hex wrench. Grasp the groove roller steady and draw out the groove shaft from the side block. Refer to Figure 5.
3. Remove Drive Roll
Loose the flush bolt in the center of drive shaft with a 5/16"(10mm) hex wrench. Grasp the knurl drive roll and draw the bolt out.
4. Reverse step 2 & 3, install suitable groove roller and drive roller as demanded.

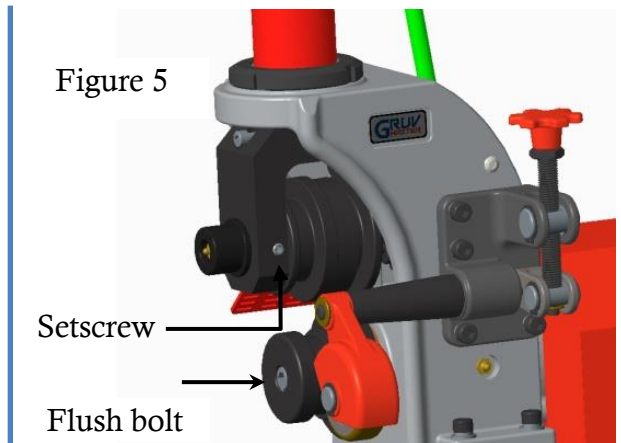
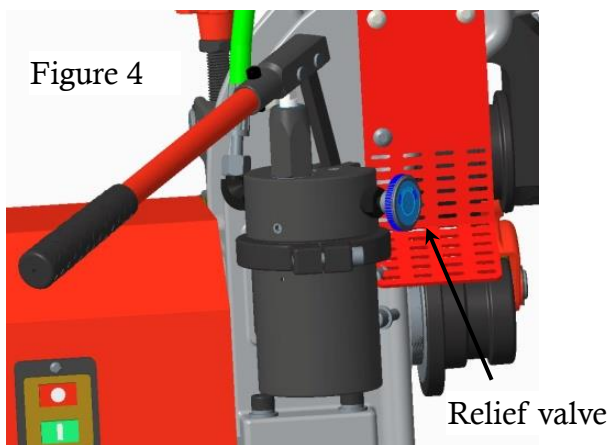

MAINTENANCE INSTRUCTIONS

Lubrication

GRUVMASTER® GHM-2X Heavy Duty Electric Hydraulic Roll Groover with good general purpose should lubrication periodically as below specified.

- 2 Grease nozzles are integrated on GHM-2X groover. Grease nozzle of Drive Shaft lubrication located on the side of the groover housing. Roll shaft nozzle at the front-center of the roll shaft. Always add grease until a small amount is pushed out.
- **At least every 4 hours of operation**, lubricate the roll shaft.
- **Every month**, add grease to the drive shaft lubrication nozzle.
- The gear box of the GHM-2X Roll Groover is greased for life and does not require the addition of any grease unless the gear box is opened. See Inspection Section for other information on maintenance.
- Grease the bearing prior assembling when repairing the roll groover.

Cleaning

- Clean the driveshaft knurls with a wire brush on a daily basis or more often if needed.
- Clean the unit surface with dry soft cotton cloth.

Machine Storage

- Store the tool in a locked area that is out of reach of children and people unfamiliar with roll groover equipment. This tool can cause serious injury in the hands of untrained users.
- Store the tool in a locked area away from moisture and corrosion material. Apply a thin coat of anti-rust liquid on moving parts and shafts are strongly recommended.

Accessories

The following GRUVMaster® products have been designed to function with the GHM-2X HD Electric Hydraulic Roll Groover. Other accessories suitable for use with other tools may be hazardous when used on the GHM-2X Hydraulic Roll Groover. To reduce the risk of serious injury, only use accessories specifically designed and recommended for use with the GHM-2X Hydraulic Roll Groover, such as those listed below.

Standard Equipment & Item Code of

GRUVMaster® GHM-2X HD Electric Hydraulic Roll Groover

- | | |
|--|---|
| ■ #99008 GHM-2X Roll Groove machine | ■ #11020 & #12008 Roller set for 8" ~ 12" |
| ■ #98012 Single phase motor --
1100W / 110-240V / 50/60Hz | ■ #98078 Pipe stand for 2" ~ 12" |
| ■ #98001 & #98002
Hydraulic pump & cylinder | ■ #98026 Foot switch |
| ■ #11022 & #12010 Roller set for 2" ~ 3" | ■ #98011 Pipe stabilizer |
| ■ #11021 & #12009 Roller set for 3½" ~ 6" | ● Optional: |
| | ● #98003 3-phase motor --
750W / 380V / 50/60H |

Troubleshooting

Problem	Cause	Correction
Pump not delivering oil, cylinder does not advance	Low hydraulic oil in reservoir	Check oil level and add hydraulic oil if necessary.
	Low quality oil, pump nuzzle blocked.	Change qualified oil and flush the oil tube.
	Seat inside the check valve worn or leak.	Loose screws and spring, knock the steel shot with proper tool and recreate sealing.
Unusual loud and sharp noise from the pipe when grooving.	Wrong position of pipe stand with long pipe causes echo..	Relocate the pipe stand to right or left.
	Pipe end not square cut with pipe axis. Pipe end scratch the drive shaft plate.	Cut pipe end square.
	Excessive friction between pipe and drive roll.	Apply a thin coat of grease on pipe end.
Pipe will not trach while grooving	Pipe not level.	Adjust stand to level pipe.
	Stabilizer wheel not engaging pipe.	Offset pipe 1°-2° and tight the stabilizer again.
	Groover not level.	Level groover.
Pipe rocks from side to side	Improper setup of pipe stand.	Adjust the pipe stand location, direction and height.
	Pipe end flattened or damaged	Cut off damaged pipe end or grind flat.

Service and Repair

The “Maintenance Instructions” will take care of most of the service needs of this machine. Any problems not addressed by this section should only be handled by an authorized GRUVMaster® service technician. Tool should be taken to a GRUVMaster® Independent Authorized Service Center or returned to the factory. When servicing this machine, only identical replacement parts should be used. Use of other parts may create a risk of serious injury. If you have any questions regarding the service or repair of this machine, please email to: customerservice@GRUVMaster.com.cn

Chart A -Roll grooving parameters

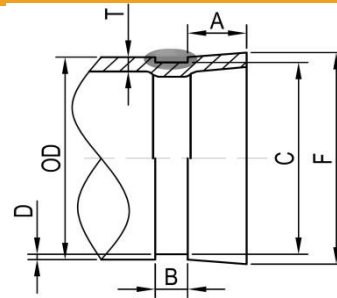
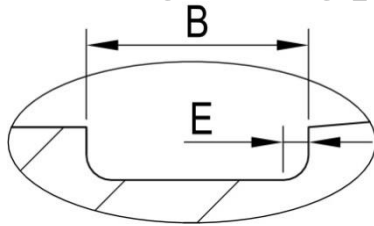

Nom. Pipe Size	Pipe O.D.			Gasket Seat A ±0.03in. ±0.76mm	Groove Width B ±0.03in. ±0.76mm	Groove Diameter		Groove Depth D(ref.) in. mm	Allow. Flare Dia. F(max) in. mm
	Basic	Tolerance				Basic	Tol.		
in. mm	in. mm	+in. + mm	-in. -mm			in. mm	in. mm	in. mm	in. mm
2" 50	2.375 60.3	0.024 0.61	0.024 0.61	0.625 15.88	0.344 8.74	2.250 57.15	-0.015 -0.38	0.063 1.60	2.48 63.0
2½" 65	2.875 73.0	0.029 0.74	0.029 0.74	0.625 15.88	0.344 8.74	2.720 69.09	-0.018 -0.46	0.078 1.98	2.98 75.7
3OD 65	3.000 76.1	0.030 0.76	0.030 0.76	0.625 15.88	0.344 8.74	2.845 72.26	-0.018 -0.46	0.078 1.98	3.10 78.7
3" 80	3.500 88.9	0.035 0.89	0.031 0.79	0.625 15.88	0.344 8.74	3.344 84.94	-0.018 -0.46	0.078 1.98	3.60 91.4
3½" 90	4.000 101.6	0.040 1.02	0.031 0.79	0.625 15.88	0.344 8.74	3.834 97.38	-0.020 -0.51	0.083 2.11	4.10 104.1
4" 100	4.500 114.3	0.045 1.14	0.031 0.79	0.625 15.88	0.344 8.74	4.334 110.08	-0.020 -0.51	0.083 2.11	4.60 116.8
4½OD 120	5.000 127.0	0.050 1.27	0.031 0.79	0.625 15.88	0.344 8.74	4.834 122.78	-0.020 -0.51	0.083 2.11	5.10 129.5
5½OD 125	5.500 139.7	0.056 1.42	0.031 0.79	0.625 15.88	0.344 8.74	5.334 135.48	-0.020 -0.51	0.083 2.11	5.60 142.2
5" 125	5.563 141.3	0.056 1.42	0.031 0.79	0.625 15.88	0.344 8.74	5.395 137.03	-0.022 -0.56	0.084 2.13	5.66 143.8
6½OD 150	6.500 165.1	0.063 1.60	0.031 0.79	0.625 15.88	0.344 8.74	6.330 160.78	-0.022 -0.56	0.085 2.16	6.60 167.6
6" 150	6.625 168.3	0.063 1.60	0.031 0.79	0.625 15.88	0.344 8.74	6.455 163.96	-0.022 -0.56	0.085 2.16	6.73 170.9
8OD 200	8.000 203.2	0.063 1.60	0.031 0.79	0.750 19.05	0.469 11.91	7.816 198.53	-0.025 -0.64	0.092 2.34	8.17 207.5
8" 200	8.625 219.1	0.063 1.60	0.031 0.79	0.750 19.05	0.469 11.91	8.441 214.40	-0.025 -0.64	0.092 2.34	8.80 223.5
10OD 250	10.000 254.0	0.063 1.60	0.031 0.79	0.750 19.05	0.469 11.91	9.812 249.23	-0.027 -0.69	0.094 2.39	10.17 258.3
10" 250	10.750 273.0	0.063 1.60	0.031 0.79	0.750 19.05	0.469 11.91	10.562 268.28	-0.027 -0.69	0.094 2.39	10.92 277.4
12OD 300	12.000 304.8	0.063 1.60	0.031 0.79	0.750 19.05	0.469 11.91	11.781 299.24	-0.030 -0.76	0.109 2.77	12.17 309.1
12" 300	12.750 323.9	0.063 1.60	0.031 0.79	0.750 19.05	0.469 11.91	12.531 318.29	-0.030 -0.76	0.109 2.77	12.92 328.2

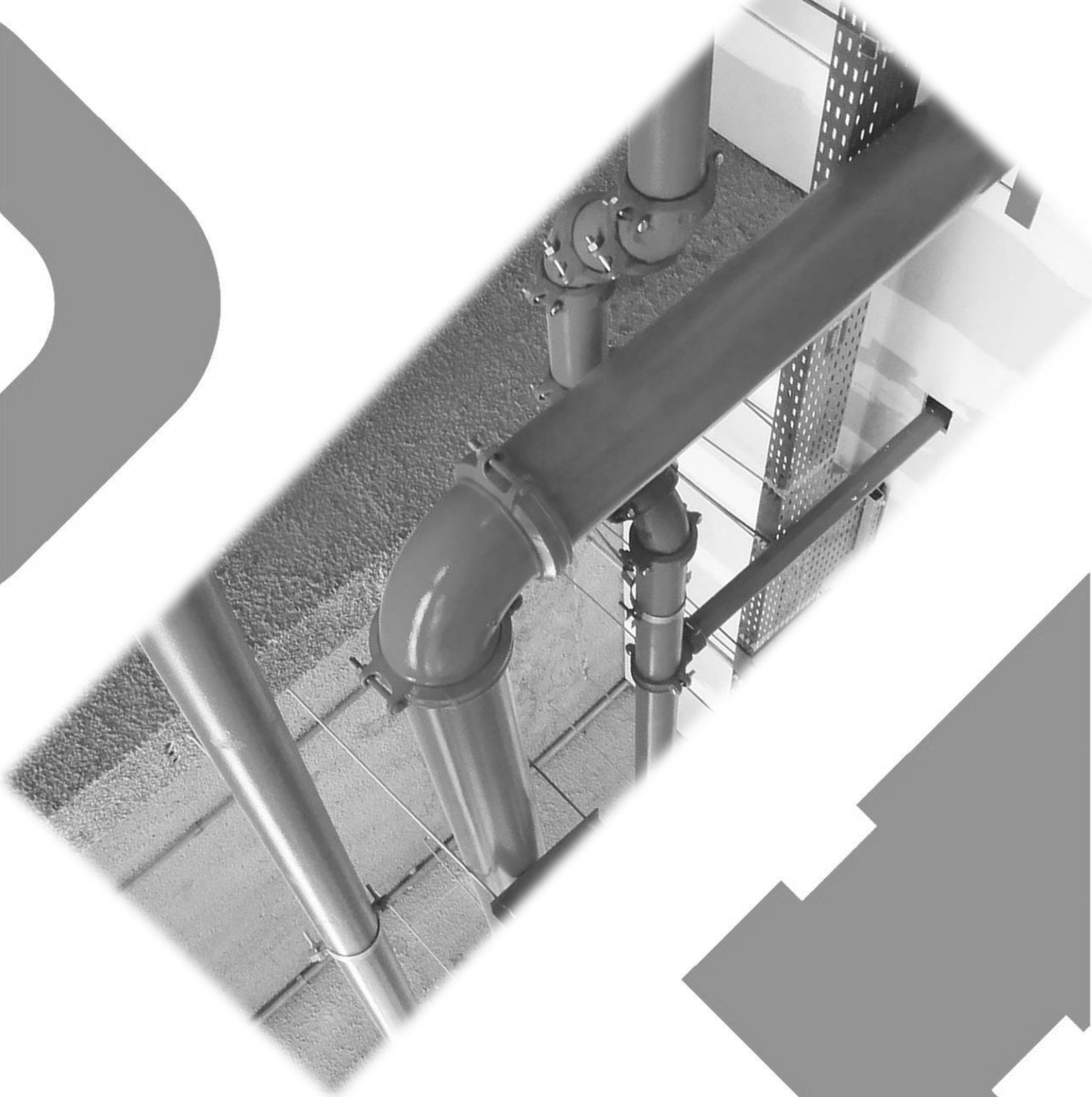

GRUVMASTER® reserves the right to change product design and specifications. Subject to change without notice.

The photos/pictures on the manual may be different from the actual product, the actual product shall prevail.

**NANTONG GRUVMASTER
CONSTRUCTION MACHINERY CO., LTD.**

ADD: No. 168 HaoSheng rd., HaiMen, NanTong city
JiangSu province. P.R. China 226145

WEB: www.gruvmaster.com.cn

E-mail: customerservice@gruvmaster.com.cn

