

# OS&Y GATE VALVE

## Flange x Flange

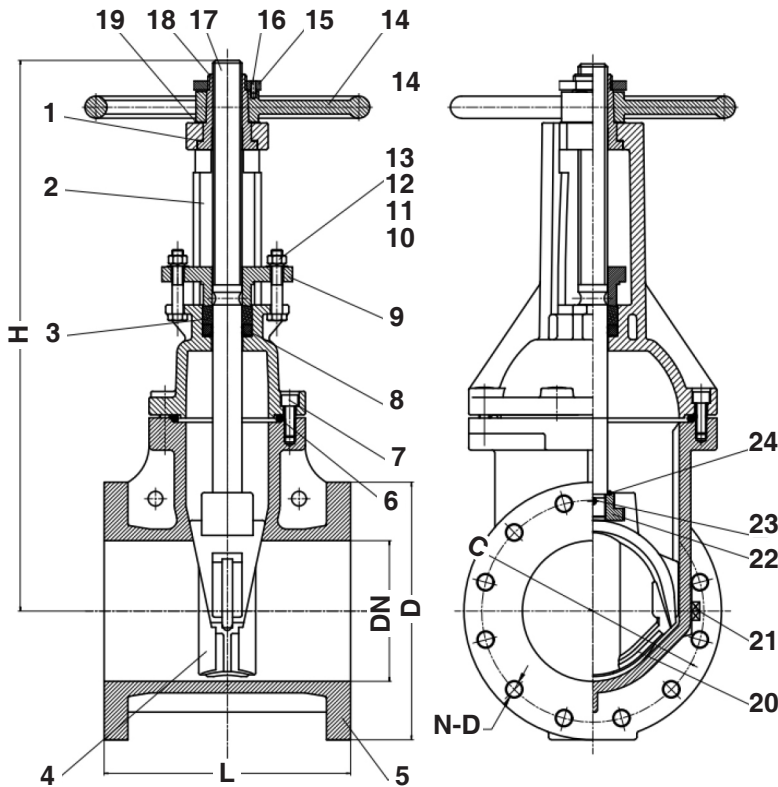

- Design Standard: AWWA C515
- Connection Ends: Flange to ASME B16.1 CL 125
- Stem drive by keys, parallel or diagonal square or flat head
- Pre-Notched Stem to Accommodate Tamper Switch
- Working Pressure: 300 PSI
- Temperature Range: 175° F
- Coating: Fusion Bonded Epoxy Coating in accordance with ANSI/AWWA C550



#	Description	Material
1	Gasket	C95400
2	Bonnet	DI
3	Packing	Graphite
4	Disc	EPDM+DI
5	Body	DI ASTM A536
6	Sealing Ring	EPDM
7	Bolt	Steel
8		
9	Gland	DI
10	Nut	Steel
11	Flat Washer	Steel
12	Bolt	Steel
13	Spring Washer	Steel
14	Handwheel	DI
15	Lock Nut	C95400
16	Locating Screw	SS 304
17	Stem	SS 304
18	Stem Nut	C95400
19	Gasket	C95400
20	Skeleton	DI
21	Plug	C95400
22	Lifting Nut	CF8M
23	Pin	SS 304
24	Sealing Ring	EPDM

ITEM #	SIZE	DN	L	D	C	N-D	H
6520260	2-1/2"	2.56"	7.48"	7.01"	5.49"	2.56"	14.57"
6520261	3"	3.15"	7.99"	7.52"	6.00"	3.15"	16.54"
6520262	4"	4.06"	9.02"	9.02"	7.50"	4.06"	17.6"
6520263	6"	6.10"	10.51"	10.98"	9.51"	6.10"	23.9"
6520264	8"	8.03"	11.50"	13.50"	11.75"	8.03"	29.69"
6520265	10"	10.04"	12.99"	15.98"	14.25"	10.04"	35.04"
6520266	12"	11.97"	14.02"	19.02"	17.01"	11.97"	40.59"

System No.		Location		Spec Section		Paragraph	
Submitted By		Date		Approved		Date	