

# data sheet



## WATER HEATER STANDS

### STANDARD



Durable 16 & 18 Ga. Galvanized Steel Construction

- WHS-1 recommended for 30-50 gallon capacity gas water heaters. 650 lb. safe working load.
- WHS-2 1300 Lb. safe working load. Legs are cross braced to prevent tipping.
- Both WHS-1 and WHS-2 models safely support water heater 18" above the floor as required by the National Fuel Gas Code and Uniform Plumbing Code.
- Stands shipped unassembled for ease in handling

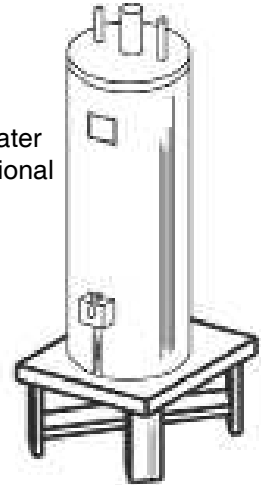

MODEL #	ITEM #	WIDTH	DEPTH	HEIGHT	GA.	MAX. LOAD (Lbs.)	WEIGHT (Lbs.)
WS-1	2545200	21"	21"	18"	18	650	15
WS-2	2545201	24"	24"	18"	16	1300	22

### ENCLOSED

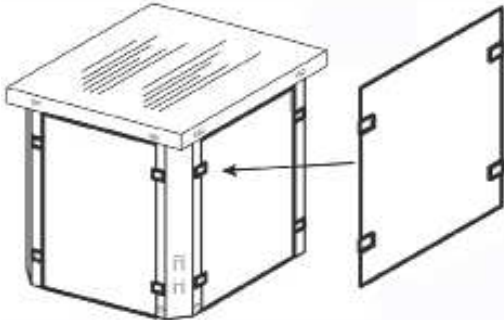

- Includes four (4) 26 ga. side panels. 650 lb. safe working load.
- Water heater stand is fully enclosed on four sides to prevent storage of flammable liquids.
- Ideal for use in food processing areas.
- Side panels easily slide into position once stand is assembled.

MODEL #	ITEM #	WIDTH	DEPTH	HEIGHT	GA.	MAX. LOAD	WEIGHT
WS-1EN	2545205	21"	21"	18"	18	650 lbs	15 lbs.

### FAST ASSEMBLY ENCLOSED

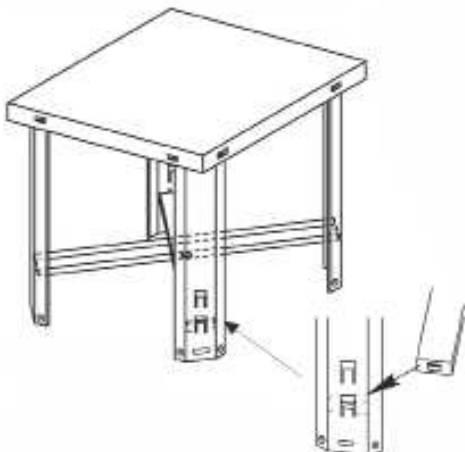

LESS ASSEMBLY TIME REQUIRED. FEWER PARTS. COMPACT SHIPPING.

- Stand assembles in 80% less time than our standard model.
- Innovative locking tab design for legs, tabletop & cross bracing attachment.
- Shipped unassembled in box protecting the stand from factory to job site.
- No need to haul a cumbersome assembled stand around.
- Legs are cross braced to prevent tipping.
- Includes four (4) 26 ga. side panels.
- Holds up to 50 gallon water heater 18" above the floor as required by the National Fuel Gas Code and Uniform Plumbing Code

MODEL #	ITEM #	WIDTH	DEPTH	HEIGHT	GA.	MAX. LOAD	WEIGHT
WS-1FAEN	2545206	21"	21"	18"	18	650 lbs	22 lbs.

FOR MORE INFORMATION CALL ARGCO AT 800-854-1015  
OR LOG ONTO ARGCO.COM