

Ductile Iron Butterfly Valve Lug Style 300PSI



Technical Features

- Connections: Lug Style Wafer Ends (ASME B16.1 Class 125)
- Sizes: 2-1/2", 3", 4", 6", 8"
- Approvals: UL, ULC, FM
- Maximum Working Pressure: 300PSI (Max. Test Pressure: 600PSI)
- Maximum Working Temperature: 176°F (80°C)
- Complies with AWWA C550
- Fusion Bonded Epoxy Coated Interior and Exterior to AWWA C550



Parts	Components	Material	Specification
1	Body	Ductile Iron	ASTM A536
2	Seat	EPDM	EPDM Grade E
3	Disc	Ductile Iron	ASTM A536 EPDM Encapsulated
4	Stem	Stainless Steel	AISI 420
5	O-Ring (All)	EPDM	EPDM Grade E
6	Bushing	Polytetrafluoroethylene	PTFE
7	Housing	Ductile Iron	ASTM A536

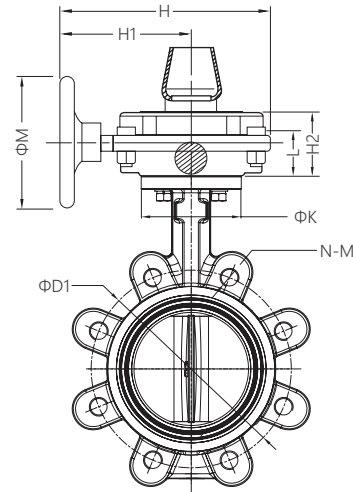
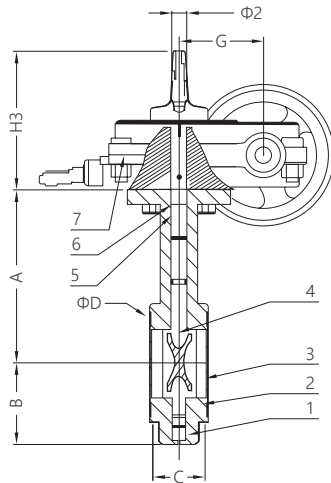

Dimensions

Size	A		B		C		N-M	D1		M		H		H1		H2		H3		K		G		D		Φ2		L	
	in	mm	in	mm	in	mm		in	mm	in	mm	in	mm	in	mm	in	mm	in	mm	in	mm	in	mm	in	mm	in	mm	in	mm
2-1/2"	6.0	153	2.8	72	1.8	46	4-5/8	5.5	139.7	5.9	150	8.2	208	5.9	151	2.6	65	4.3	108	3.5	90	2.3	59	2.6	65.2	0.6	14	1.3	32
3"	6.2	157.5	3.4	86	1.8	46	4-5/8	6.0	152.4	5.9	150	8.2	208	5.9	151	2.6	65	4.3	108	3.5	90	2.3	59	3.1	79.7	0.6	14	1.3	32
4"	6.9	176.0	3.9	100	2.0	52	8-5/8	7.5	190.5	5.9	150	8.2	208	5.9	151	2.6	65	4.3	108	3.5	90	2.3	59	4.1	105.0	0.6	14	1.3	32
6"	8.0	202.5	5.0	128	2.2	56	8-3/4	9.5	241.3	5.9	150	8.2	208	5.9	151	2.6	65	4.3	108	3.5	90	2.3	59	6.1	155.8	0.8	20	1.3	32
8"	9.6	243.5	6.4	162	2.4	60	8-3/4	11.8	298.5	7.9	200	11.7	298	8.8	223	3.0	77	4.8	121	4.9	125	3.1	77.5	8.1	206.7	1.0	26	1.8	45

System No.		Location		Spec Section		Paragraph	
Submitted By		Date		Approved		Date	