

# SWING CHECK VALVE GROOVED



[CLICK HERE TO PURCHASE](#)



## Technical Features

- Connection Ends: Groove to AWWA C606
- Working Pressure: 300 PSI
- Temperature Range: 32° to 176° F
- Coating: Fusion Bonded Epoxy Coating in accordance with ANSI/AWWA
- Designed for Fire Protection Systems
- Prevents backflow
- Single-disc mechanism incorporates a spring-assisted feature for non-slamming operation.
- Can be installed either vertically (flow upwards only) or horizontally.
- Valve body cast with arrow indicator to assist with proper valve orientation.
- Provided with grooved ends.
- Rated for ambient temperature use in fire protection systems.



PART	COMPONENT	MATERIAL	SPECIFICATION
1	BODY	Ductile Iron, Epoxy Coated	ASTM A536 65-45-12
2	CLAPPER	Stainless Steel	ANSI 304
3	COIL SPRING	Stainless Steel	ANSI 302
4	NUT	Stainless Steel	ANSI 304
5	BOLT	Stainless Steel	ANSI 304
6	WASHER	Rubber	ANSI 304
7	FACING SEAL	Stainless Steel	ANSI 304
8	SEAT RING	Ductile Iron	EPDM
9	DRAIN PLUG	Ductile Iron	ANSI 304
10	PIN PLUG	Aluminum Bronze	Drain Plug
11	BUSHING	Stainless Steel	Bushing
12	HINGE PIN	Steel	Hinge Pin
13	HOOK		Hook
14	OIL RING		EPDM
15	WASHER		ASTM A-307

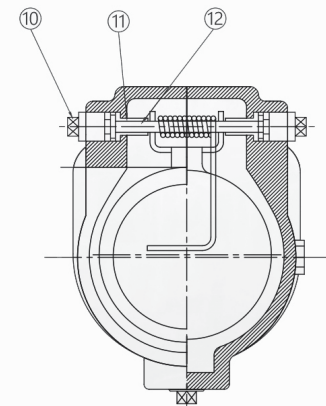
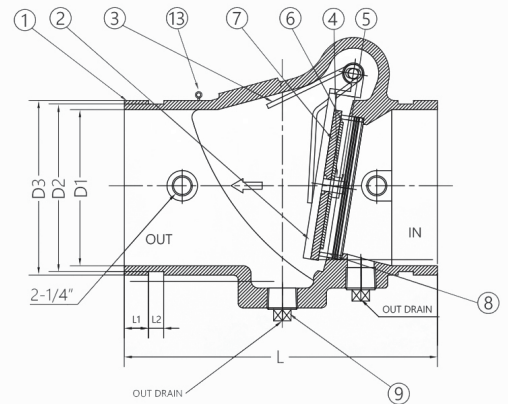

## DIMENSIONS

ITEM #	SIZE	D1	D2	D3	L	L1	L2
6520200	2"	1.9"	2.2"	2.4"	6.7"	0.6"	0.3"
6520201	2-1/2"	2.4"	2.7"	2.9"	7.2"	0.6"	0.3"
6520202	3"	2.9"	3.3"	3.5"	7.6"	0.6"	0.3"
6520203	4"	3.9"	4.3"	4.5"	8.1"	0.6"	0.3"
6520204	6"	6.1"	6.4"	6.6"	12.6"	0.6"	0.3"
6520205	8"	7.9"	8.5"	8.6"	14.6"	0.8"	0.4"
6520206	10"		10.6"	10.7"	18.0"	0.8"	0.5"
6520207	12"		12.5"	12.8"	21.1"	0.8"	0.5"

System No.		Location		Spec Section		Paragraph	
Submitted By		Date		Approved		Date	

# SWING CHECK VALVE GROOVED



## Check Valve Flow Performance:

**Cv Value:** The Cv value refers to the number of U.S. gallons of water that flow through a valve per minute at 60°F (15.6°C) when the pressure drop across the valve is 1 psi (pound per square inch).

$$CV = \frac{Q \times \sqrt{SG}}{\sqrt{\Delta P}}$$

**Q:** The flow rate of the fluid, measured in gallons per minute (GPM).

**SG:** The specific gravity of the fluid, defined as the ratio of the fluid's density to the density of water. For water, SG = 1.

**ΔP:** The pressure drop across the valve, measured in psi.

**Kv Value:** The Kv value refers to the number of cubic meters of water that flow through a valve per hour at a water temperature of 15°C when the pressure drop across the valve is 1 bar.

$$CV = 1.156KV$$

**Pressure Drop-Flow Rate Chart**

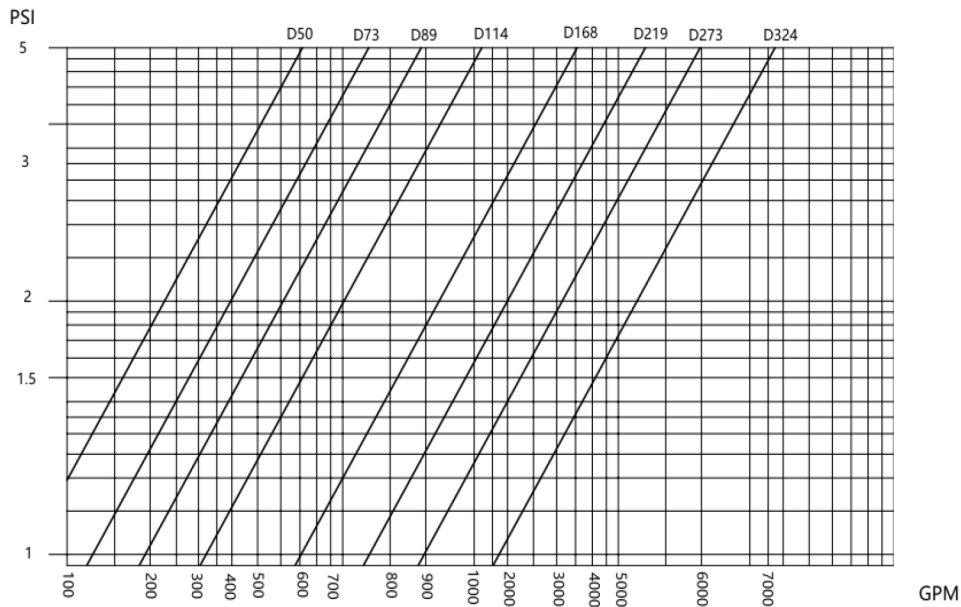

**Size-Flow Characteristics Chart**

DN	D50	D73	D89	D114	D168	D219	D273	D324
<b>Kv</b>	86	145	195	392	1105	1756	2967	5244
<b>Cv</b>	100.362	169.215	227.565	457.464	1289.54	2049.25	3462.49	6119.75

System No.		Location		Spec Section		Paragraph	
Submitted By		Date		Approved		Date	